



HYMER

DE **Ausstieg breit mit Übergang**

Montageanweisung

EN **Wide exit with crossover**

Assembly instruction

FR **Sortie évasée avec passage acrotère**

Instructions de montage

ES **Salida ancha con puente**

Instrucciones de montaje

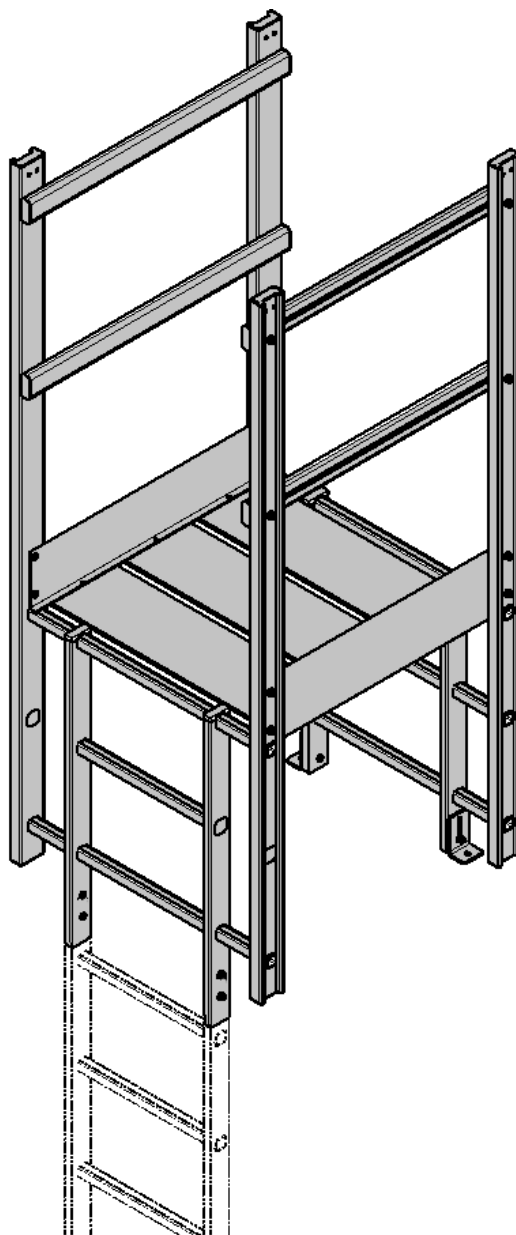

0054056

0054057

0054058

0055575

0055576

0055577

Hymer-Leichtmetallbau GmbH & Co. KG

Käferhofen 10 | 88239 Wangen | GERMANY

Tel. +49 (0)75 22 700-702

technical-sales@hymer-alu.de | www.hymer-steigtechnik.de

Pos.	0054056	0054057	0054058	0055575	0055576	0055577
1	1x	1x	1x	1x	1x	1x
2	1x	1x	1x	1x	1x	1x
3	1x	-	-	-	-	-
4	-	1x	-	-	-	-
5	-	-	1x	-	-	-
6	-	-	-	1x	-	-
7	-	-	-	-	1x	-
8	-	-	-	-	-	1x
9	4x	-	-	4x	-	-
10	-	4x	-	-	4x	-
11	-	-	4x	-	-	4x
12	2x	2x	2x	2x	2x	2x
13	2x	2x	2x	2x	2x	2x
14	18x	18x	18x	18x	18x	18x
15	8x	8x	8x	8x	8x	8x
17	4x	4x	4x	4x	4x	4x
18	10x	10x	10x	10x	10x	10x
19	20x	20x	20x	20x	20x	20x
21	1x	1x	1x	1x	1x	1x

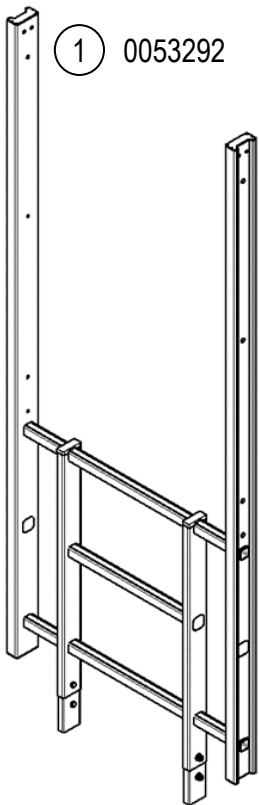

① 0053292

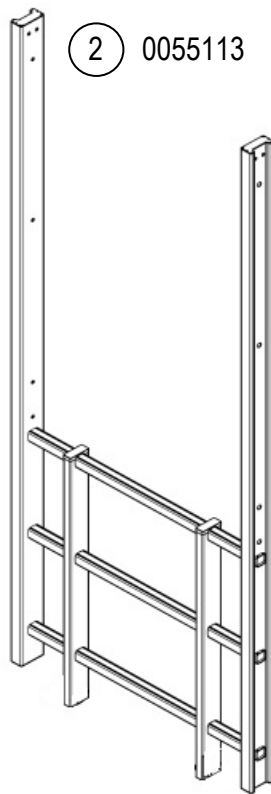

② 0055113

③ 0053305

④ 0053306

⑤ 0053307

⑥ 20001717

⑦ 20001718

⑧ 20001719

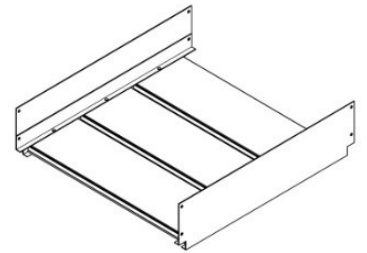

⑨ 0053662

⑩ 0053663

⑪ 0053664

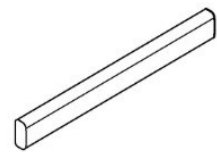

⑫ 20000916

⑬ 20001679

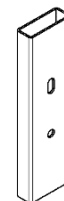

⑭



Ø12 x Ø8,4 x 22
004388

⑮

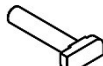

M8 x 40
006485

⑰



M8 x 35
006297

⑱



M8 x 40
006298

⑲



M8
006700

⑳



0095642



1.

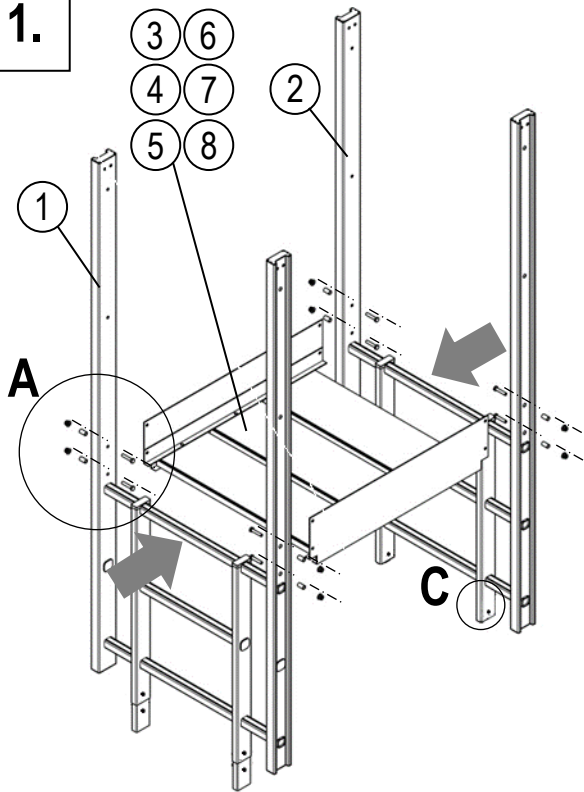

 M8:  18 Nm

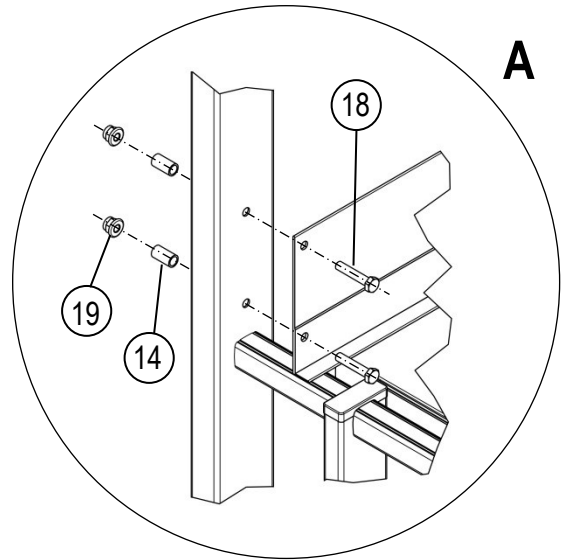

2.

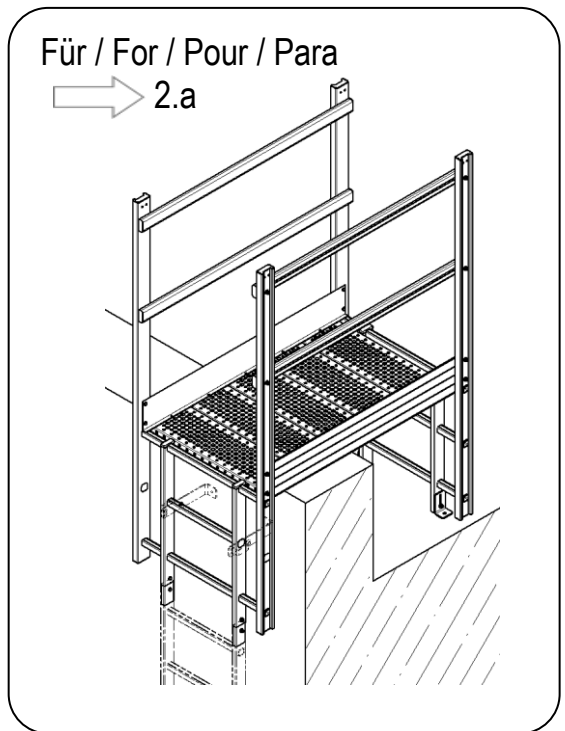
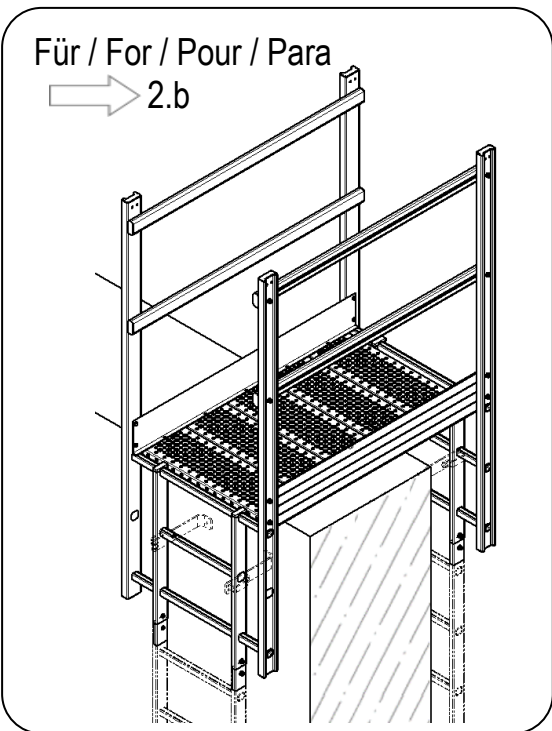

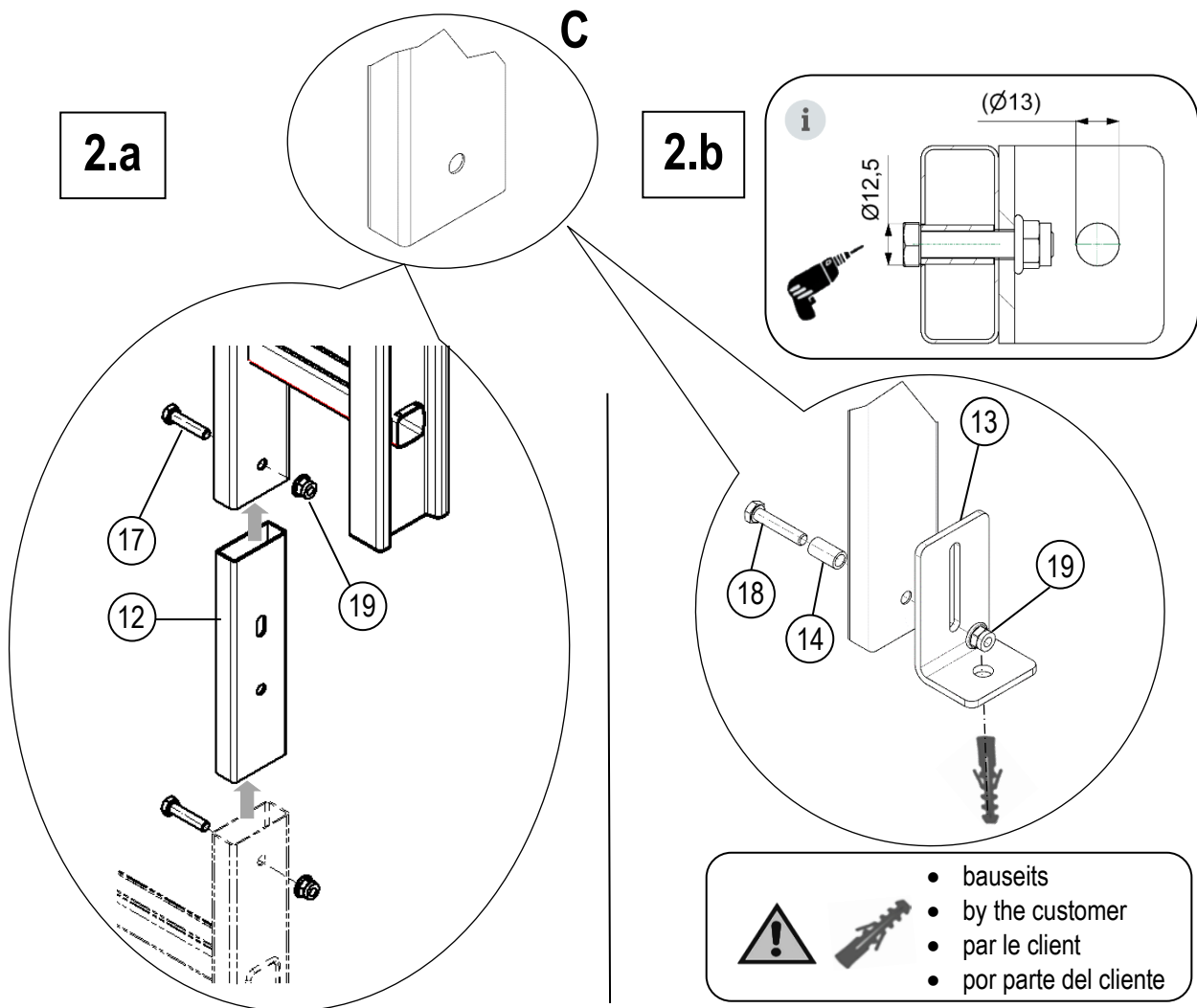

DE

Es dürfen nur Dübel-Systeme bzw. Befestigungen mit bauaufsichtlicher Zulassung verwendet werden. Das Bau- bzw. Tragwerk sowie der Baugrund müssen ausreichend tragfähig sein. Die Montagefirma ist für die Ausführung verantwortlich und hat die Tragfähigkeit des Mauerwerks durch einen Bausachverständigen zu prüfen. Bezüglich Auswahl der Dübel setzen Sie sich bitte mit einem Dübelhersteller in Verbindung und beachten Sie deren Vorschriften.

Die Montage ist durch einen Bausachverständigen während der Montage zu überprüfen. Verbindungsmaterial, Wandbefestigungen und Dübel gehören nicht zum Lieferumfang. Unfallverhütungsvorschriften sind zu beachten.

EN

Only wall anchor systems or attachments may be used if approved by building regulations. The building or structure and also the foundation must be sufficiently capable of bearing the load. The installation company bears responsibility for the type of attachment and should have the load bearing capacity of the wall checked by a building surveyor. When selecting the wall anchor system, contact the anchor system manufacturer and observe the manufacturer's regulations. Installation should be checked by a building surveyor while the installation is performed. Joining material, wall attachments and anchors are not included in the items supplied. Observe accident prevention regulations.

FR

Il ne faut utiliser que des assemblages ou fixations à cheville qui sont autorisés par l'office chargé de la surveillance des travaux publics. L'ouvrage ou la structure porteuse doivent être suffisamment solides. La compagnie de montage est responsable de l'exécution et doit faire vérifier la charge admissible de la maçonnerie par un expert en matière de construction. En ce qui concerne le choix des chevilles, veuillez contacter un fabricant de chevilles et respecter ses consignes. Un expert en matière de construction doit vérifier le montage pendant le montage. Les matériaux de liaison (fixations murales spécifiques, chevilles et visserie adaptées au support) ne sont pas inclus dans le contenu de la livraison. Respecter SVP les instructions préventives contre les accidents.

ES

Solo está permitido el uso de sistemas de tacos o fijaciones con homologación para obras. La construcción o la estructura portante, así como la base, tienen que poseer suficiente capacidad de carga. La empresa de montaje es responsable de la ejecución y debe encargarse de la verificación de la capacidad de carga del muro a un perito de obra. Respecto a la elección de los tacos, por favor, consulte al fabricante de los tacos y siga sus especificaciones. El montaje debe ser supervisado por un perito de obra durante la realización del mismo. El material de unión, las fijaciones murales y los tacos no forman parte del volumen de suministro. Es obligatorio el cumplimiento de la normativa sobre prevención de accidentes.